



GO-DEVIL[®]

SURFACE DRIVE

FNR

— **INSTRUCTIONS** —

**Operation and
Service Manual**

May 2023

****Updated Gearbox Lubrication Instructions****

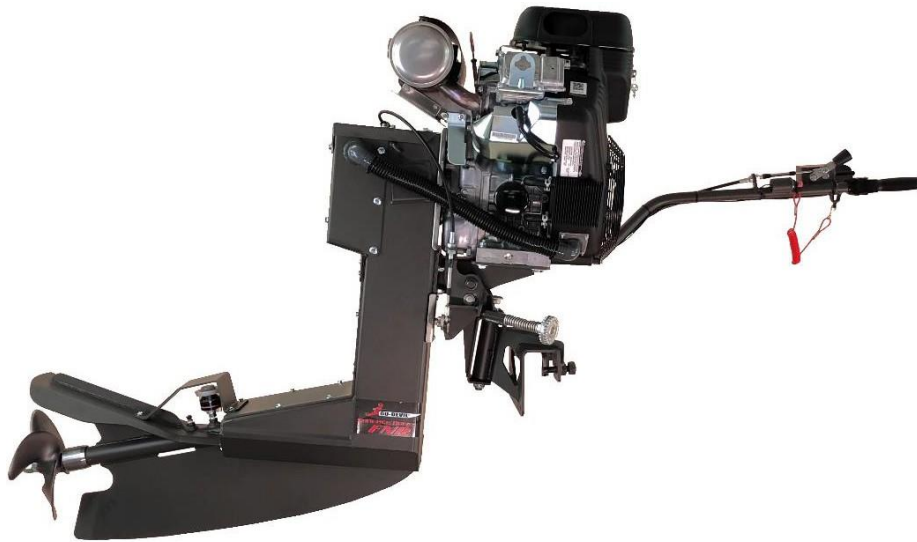

GO-DEVIL[®] Manufacturing Company of Louisiana LLC
(225) 752-0167 • Toll Free 1-888-490-3254 • Fax (225) 752-0175
18649 Womack Road • Baton Rouge, LA 70817
Please visit our website at www.godevil.com

SURFACE DRIVE SAFETY

- **GASOLINE IS EXTREMELY FLAMMABLE!** Always handle in properly approved containers. Spilled fuel could ignite if it comes in contact with a hot engine or sparks!
- **DO NOT LEAVE ANY FUEL TANK CONNECTED WHEN THE BOAT IS NOT IN USE. TANKS SOLD AFTER JULY 2011 DO NOT HAVE A STANDARD VENT!** Heat from the sun's radiation will build pressure inside the fuel tank and will force fuel through the carburetor and into the crankcase. At this point the crankcase will become over full and will blow oil into the air cleaner from the breather. After the air cleaner becomes saturated with oil, the fuel mixture will become too rich and will foul the spark plugs.
- **KEEP HANDS, FEET, HAIR, AND CLOTHING AWAY FROM ANY MOVING PARTS** to prevent accidents while engine is running both in the water and, most importantly, while on land!
- **WARNING!!** – The trim knob is angled outward and away from a pinch point between the engine and transom bracket. **DO NOT PLACE HANDS BETWEEN ENGINE AND TRANSOM BRACKET WHILE ENGINE IS RUNNING!!!** If the skeg or prop strikes an obstruction while underway, the engine may tilt violently and cause injury.
- **NEVER TOUCH ENGINE COMPONENTS DURING OR IMMEDIATELY AFTER OPERATION.** Components can become extremely hot which could result in severe burns!
- **NEVER RUN YOUR SURFACE DRIVE IN AN ENCLOSED AREA!** Exhaust gases contain poisonous carbon monoxide! Always test run in a well-ventilated area.
- **ALWAYS OPERATE YOUR SURFACE DRIVE WITH THE SAFETY KILL SWITCH LANYARD ATTACHED TO YOUR WRIST OR BELT LOOP!** After warm up, always test your safety kill switch to make sure it is operating properly!
- **OPERATE YOUR SURFACE DRIVE FROM A SITTING POSITION,** unless you install a grab bar in your boat to operate while standing!
- **BE ALERT FOR HAZARDS AT ALL TIMES!** Shallow water areas in particular can present a variety of challenges. Continually read the terrain for unexpected obstructions, turns, or changes in water depth.
- **KEEP YOUR SURFACE DRIVE IN A SAFE CONDITION.** It is important to keep your engine properly maintained. Having a breakdown can be difficult, especially if you are far away from help or land. To help avoid problems, inspect your engine before each use and perform all recommended maintenance.

TABLE OF CONTENTS

SURFACE DRIVE SAFETY

ASSEMBLY AND BOAT SETUP	1-4
• Crate Removal.....	1-2
• Boat Setup.....	3-4
• Bolting Engine to Transom.....	3
OPERATION INSTRUCTIONS	5-9
• Surface Drive Features	5
• Launching, Engine Starting.....	6
• Low Speed Operation	7
• High Speed Operation, Trim Adjustment.....	7-8
• Reverse Operation on Go-Devil Surface Drive FNR	9
LUBRICATION	10-12
• Engine Lubrication.	10
• External Grease Fittings.....	10
• Pressure Lubrication	11
• Internal Drive Lubrication	12
BELT TENSION AND INSTALLATION	13-15
• Tension Tester...How it Works!	13
• Checking Belt Tension	14
• Adjusting Belt Tension, Replacing belt	15
SPECIAL TOOLS TO SERVICE SURFACE DRIVES	16
CHANGING TRANSMISSION OIL	17
CLUTCH AND TRANSMISSION REMOVAL	18-19
CLUTCH AND TRANSMISSION INSTALLATION	19-21
LOWER SEAL REPLACEMENT	22
INSTALLING THE LOWER SEAL HOUSING	23
PROPELLER REMOVAL/INSTALLATION	23
SHAFT REMOVAL/INSTALLATION	24
BUSHING REMOVAL AND INSTALLATION	25
SURFACE DRIVE FNR LOWER DRIVE ASSEMBLY	26
SERVICE MEMOS	27
WARRANTY	

TO THE NEW OWNER

Dear Customer,

You have just purchased one of the toughest pieces of marine equipment ever built. The GO-DEVIL Surface Drive will give you many years of service with very little maintenance. Of the few problems that occur, most are due to dirty fuel or not running the engine out of fuel at the end of the season. We have found that unleaded gasoline will gum the carburetor in a few months if your engine is not in use. We recommend adding a fuel stabilizer such as Briggs & Stratton part number 100117(4oz) 100119A(32oz) to the fuel in your last full tank of the season. Always disconnect the fuel hose from the tank and run the engine completely out of fuel before storage **if your engine has a carburetor!** **Fuel injected engines do not need to be run out of gas but add stabilizer and disconnect the battery and fuel tank.** Fuel tanks should also be checked periodically for water which may appear from condensation. We recommend using a transom mounted water separating fuel filter (Sierra part # 18-7852-1 or equivalent) to collect water before it reaches the engine.

ASSEMBLY AND BOAT SETUP

1. Lay the crated engine flat with the engine in a normal upright position.
2. Remove the plywood and 2x4's surrounding the engine.
3. Locate the metal band holding down the prop end of the Surface Drive frame and cut it with a pair of tin snips or remove the nails with a claw hammer.
4. Remove the plastic wrapping from the engine.
5. Inspect the engine for freight damage and contact our office immediately if anything seems damaged. Note that the tail end of the skeg just in front of the propeller is factory bent. This bend is designed to compensate for torque created by the surfacing propeller.
6. Loosen the transom clamping studs located under the engine.
7. Locate the lifting eyes on the frame just below the muffler. Using the lifting eyes, hoist the engine vertically from the crate and place it onto the transom of your boat.
8. Center the engine on the transom measuring from the outside gunnel rails of the boat to the edges of the transom bracket. Tighten the clamping studs using a crescent wrench or 1-1/16" wrench or socket (15/16" wrench for galvanized models).
9. Remove the tiller handle from the frame by cutting all plastic tie-wraps that have not been trimmed.

10. The 3/8"x 2-1/2" pivot bolt indicated by the arrow in **(Fig. 1)** is the pivot point for the Adjustable/Floating handle. Remove the bolt and insert the handle into the engine-mounted handle bracket. Reinstall the bolt into the bracket, passing it through the hole at the end of the handle. Be sure to include the wire loom to secure the cables as it was shipped. Install the washer and nut and tighten the nut firmly or until a slight amount of drag can be felt while pivoting the handle up and down from the grip.

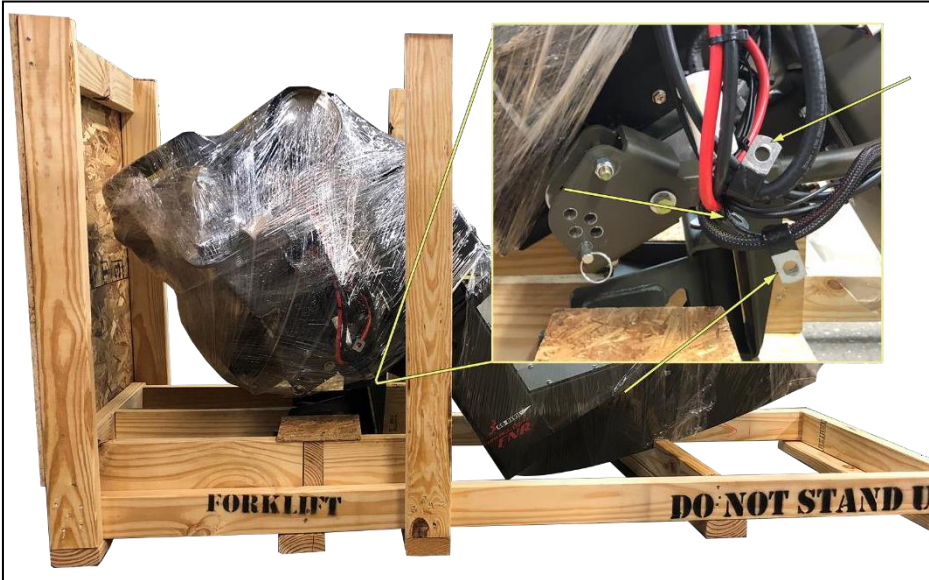

37 hp Vanguard Shown

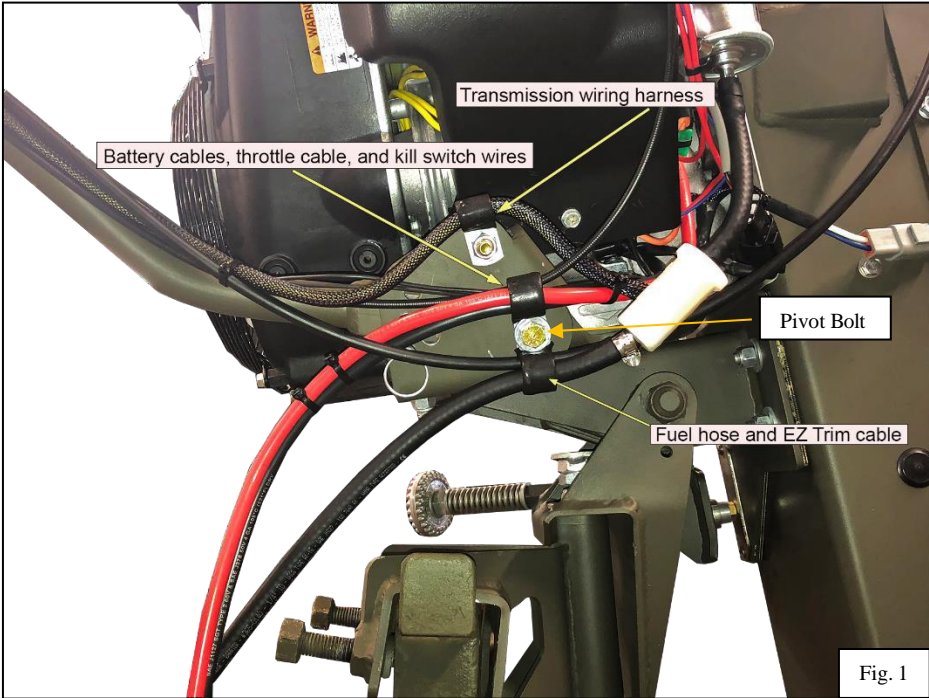

Check to ensure that the throttle linkage on the engine moves throughout its full range when the throttle lever is depressed and that it returns to the idle position when released.

For added safety, a stainless-steel throttle return spring has been installed on engines with a carburetor during factory assembly. This spring returns the throttle linkage to idle position when the squeeze lever is released. To ensure that the throttle operates smoothly on engines with a carburetor, periodically lubricate the throttle linkages with a WD-40 type spray lubricant. This is not necessary for an EFI engine. For freezing temperatures, stand the handle in a vertical position and inject antifreeze into the throttle cable with a hypodermic needle and work the throttle back and forth. This will keep any moisture from freezing your throttle.

12. Bolt the engine to the transom as described below.

ATTENTION: The Go-Devil Surface Drive engine MUST BE BOLTED TO THE TRANSOM!!!! Failing to do so will cause the transom clamp to loosen while trailering, allowing the engine to possibly fall off of the transom!!!!

BOLTS MUST PASS THROUGH A STRUCTURAL CROSS-MEMBER OF THE TRANSOM!!! (channel, tube, rib, etc.)

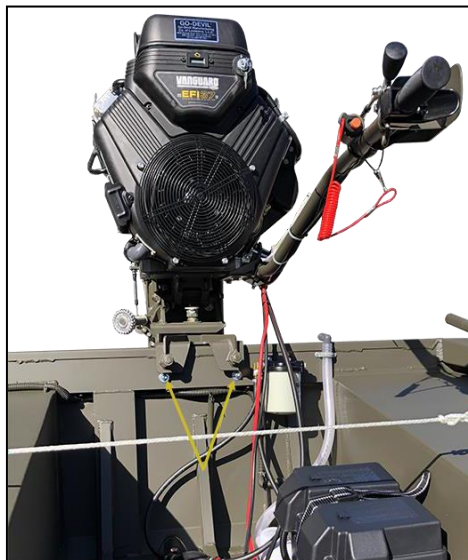

Looking from the rear of the engine, notice that the transom clamp has two horizontal rows of holes. Either the two upper or two lower holes need to be used to secure the engine to the transom. Four holes are provided to accommodate various transom designs.

Using a 3/8" drill bit, drill through the lowest hole pattern on the bracket which would allow the bolts to pass through a structural cross-member of the transom. Install the two supplied 3/8" x 3" bolts, washers and nylon insert nuts. For Go-Devil boats, the engine should be bolted to the transom using the two top holes.

13. Tie a rope to the rib in your boat under the loop welded on the underside of the Surface Drive handle. Attach the clip provided with the engine to the rope and use it to hold the Surface Drive handle as shown in the picture to the right. This clip should be used for launching your boat or any time you need to hold the prop out of the water. **(It MUST not be used when the boat is being trailered.)**

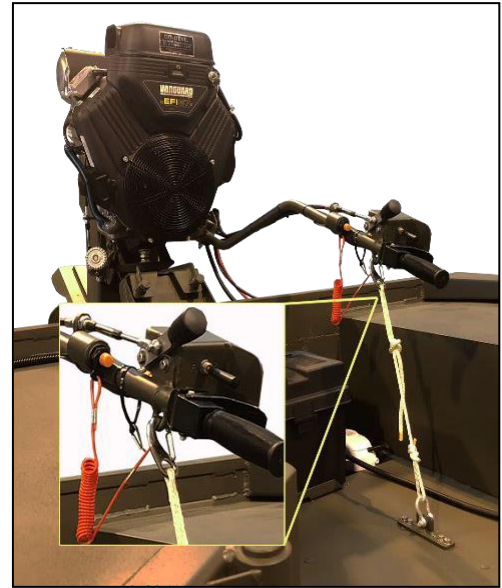

14. Connect the battery cables to the battery. Attach the red cable to the positive (+) side of the battery and attach the black cable to the negative (-) side of the battery. Make sure to tighten the battery cables with a wrench and not just hand tight. The battery should be kept in a covered battery box secured to the floor of the boat and away from gasoline vapors.

15. We recommend using a good nylon rope to tie your boat instead of a boat strap. Tie the rope to the trailer frame on one side of the boat even with the hand grip. Bring the rope over the boat, then tie a loop in the rope before the rope comes down the side of the boat. Bring the rope around the trailer frame and back up to the loop, cinch the rope tight and tie it off.



This procedure will hold your boat as tight as any boat strap so it will not bounce when trailering. We also recommend that you tie a red flag or the Go-Devil Flag included with your purchase to the tail end of the Surface Drive

when towing your boat down the highway.

16. To tie down the engine for trailering use a ratchet strap attached to one boat handle then make a wrap around the frame as shown above making sure not to wrap the strap on top of the cover bolts and then attach the strap to the other boat handle on the other side of the boat. **Do not tie the Surface Drive FNR engine handle down for any reason while trailering!**

SURFACE DRIVE FNR OPERATION INSTRUCTIONS

Surface Drive Features

37- 40 HP SHOWN

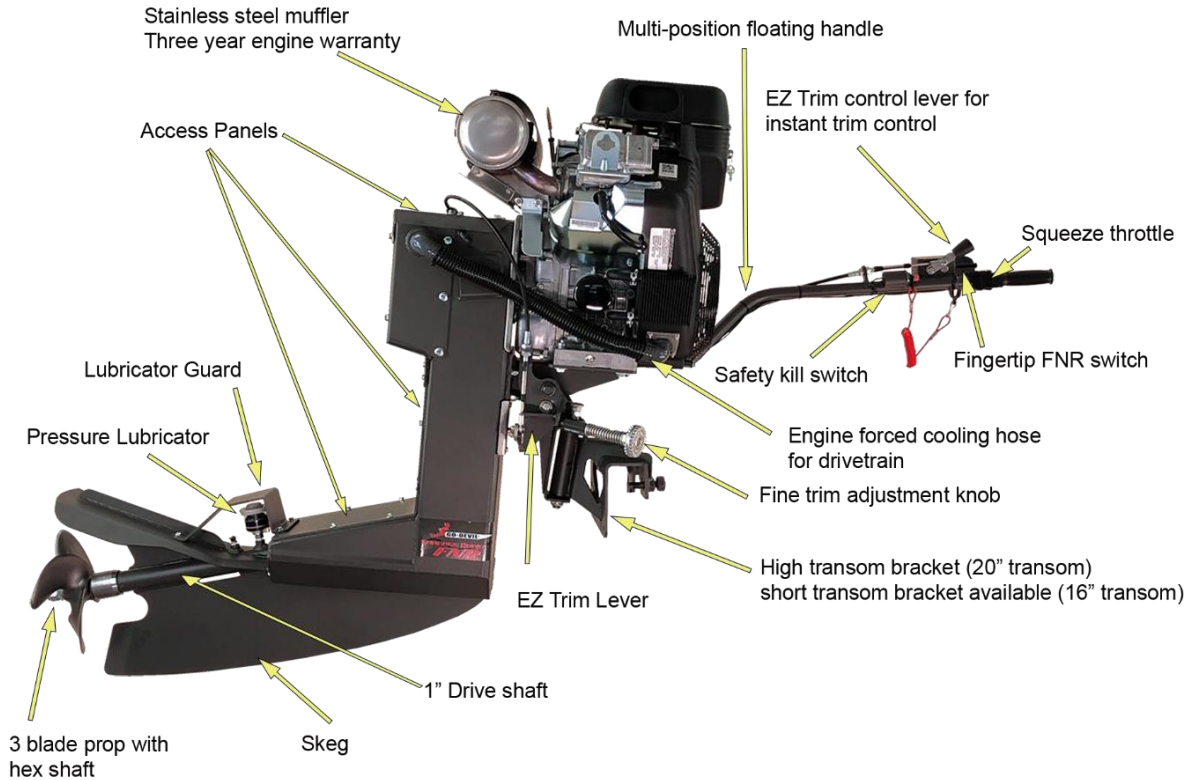

ENGINE OIL

Fill the engine crankcase with the recommended amount and type of oil. With the engine held perfectly level, check the oil level with the dip stick. Use a high detergent motor oil of the same viscosity you are using in your car or truck for that time of the year. In warm temperatures we recommend to use straight 30 weight oil. This will reduce oil consumption.

Notice: For 23 Vanguard models it is important that the crankcase is not over filled with oil. Over filling the crankcase will cause a decrease in vacuum at high speed, preventing the carburetor from supplying an adequate amount of fuel to the engine. When this happens, the engine will starve for fuel and temporarily lose performance. Ensure that the engine oil level does not exceed the full level line on the dipstick.

FUEL

Fill the fuel tank with clean, fresh gasoline from a clean fuel can. Connect the fuel line from the engine to the fuel tank and squeeze the primer bulb until firm. If the tank has a vent (tanks sold before July 2011), the vent must stay open during operation. If you purchased your tank July 2011 or after, disconnect your tank anytime it is not in use because the tank does not have an open vent.

BASIC OPERATION

Launching

When launching your boat always leave the handle rope clipped with the shaft in a horizontal position.

Before starting the engine on the water, always put on your life vest as you would in any boat with any engine.

Attach the safety kill switch lanyard to your belt loop or wrist.

Starting the Engine

ALWAYS check engine oil level before starting!!

WARNING!!

Never run the engine in an enclosed area! Exhaust contains poisonous carbon monoxide gas that may cause a loss of consciousness and/or death!

To Start the engine, FNR switch must be in the neutral (center position) to start. Pull the choke rod to the choke position if your engine is a carbureted model. If you have an EFI engine wait 5 seconds before starting. You will hear the fuel pump stop priming. Turn the key to the start position. It may be necessary to run the engine on choke for a few seconds until the engine warms up. You should run the engine for a few minutes to ensure that it runs properly. If the engine runs rough after warm up, the carburetor may need adjustment. (Refer to the engine Manual.)

To Stop the engine, release the throttle and allow the engine to idle for a few seconds. Turn the key switch to the OFF position.

EMERGENCY STOP! The engine may be stopped at any time by pulling and detaching the emergency kill switch lanyard from the kill switch. **Note: It is the operator's responsibility to ensure that the kill switch operates properly before each use.**

CAUTION! – Lowering the propeller into the water or shifting into forward at a high engine rpm may cause a standing operator or passenger to lose balance or be ejected from the boat. **ALWAYS ALLOW THE ENGINE TO COME TO IDLE OR SHIFT INTO NEUTRAL BEFORE LOWERING THE PROPELLER INTO THE WATER!**

NOTE: AFTER YOUR FIRST TEST RUN ON THE WATER IT IS NECESSARY TO REMOVE THE DRAIN PLUG (SHOWN ON PAGE 10) AT THE REAR OF THE DRIVE HOUSING TO CHECK FOR WATER LEAKING IN. THIS BOX MUST RUN COMPLETELY DRY. IF WATER COMES OUT OF THE DRAIN PLUG THE COVER PLATES MUST BE REMOVED AND RE-SEALED WITH A GOOD GRADE SILICONE. PERFORM THIS CHECK ANY TIME THE COVERS ARE REMOVED AND REPLACED.

Low Speed Operation

As described before, let the engine warm up for a few minutes. Holding the handle carefully, remove the handle rope and get a feel for the balance of the engine.

For the first time operating your new Surface Drive engine, turn the trim adjustment knob counterclockwise until the prop and cavitation plate can be fully submerged while the boat is floating at rest. Under normal conditions the trim can be adjusted for high speed performance and does not need to be changed while idling or getting back up on plane.

Steer the engine slowly to avoid getting water into or overturning the boat. The Go-Devil Surface Drive engine is better suited for wider bottomed boats (48” or wider). Use extreme caution- even while idling -when making sharp turns on narrow boats.

To turn the boat around in a tight situation, allow the boat to nearly come to a complete stop. While the engine is idling and in neutral, turn the engine all the way to one side and shift into forward. Most boats will turn in their own length when this is done.

TIP! - Turning left at low speed requires less reach due to the handle being on the left side of the engine. When reversing direction from rest or idle speed, set up to turn left whenever possible. This will become instinctive with time.

High Speed Operation

As its name implies, the Go-Devil “Surface Drive”, uses a surface piercing propeller. The surface propeller is designed to be run primarily with a fraction of each blade breaking the surface of the water with each revolution. To get maximum performance from the engine, propeller depth can be fine tuned using the manual trim.

The manual trim mechanism is a standard feature on all SD models. The trim is simply a bottom stop on the tilt axis of the engine which allows the engine to tilt upward freely when an underwater obstacle is struck.

Manual Trim Adjustment

WARNING!! – The trim knob is angled outward and away from a pinch point between the engine and transom bracket. **DO NOT PLACE HANDS BENEATH THE ENGINE WHILE IT IS RUNNING!!!** If the skeg or prop strikes an obstruction while underway, the engine may tilt violently and cause injury. With the boat floating at rest, set the trim low enough to fully submerge the propeller and cavitation plate below the waters surface. After getting up on plane and to full throttle, take notice of the propeller depth.

Trim the engine up until maximum performance and comfort is achieved. For the average boat and engine combination, the prop should be run with approximately 1/3 of its diameter above the surface. (Shown below) Different hull designs and horsepower to weight ratios will affect optimum propeller depth and performance while on plane. If necessary, the drive ratio may be reduced to accommodate extremely large hulls and loads.

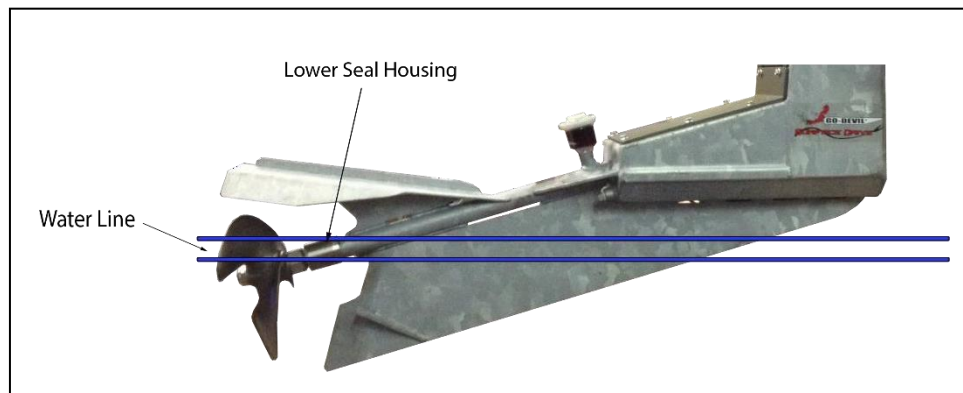

Starting on May 15th, 2008 all Surface Drive Engines are equipped with an EZ Trim Lever. The EZ Trim Lever allows the prop height to be dropped approximately 9” without adjusting the manual trim knob. This allows a smooth and efficient transition between your trim height for running on plane and “digging” out of a situation where you are stuck or in extremely shallow water. Simply push down on the Surface Drive handle and flip down the EZ Trim Lever to drop your prop height. After getting on plane and you are in a sufficient water depth, push down on the Surface Drive handle again and flip the EZ Trim Lever back up to come back to your normal trim height.

An engine mounted tachometer/hour meter is a highly recommended accessory since it allows you to view both engine rpm and total run time. Maximum performance will generally be achieved between 3400-3800 RPM since the engines make maximum horsepower within this range. Idle RPM should be 1100-1200 out of the water and 900 RPMs in the water at idle.

Reverse Operation on Go-Devil Surface Drive FNR

After the engine warms up, shift the engine into reverse by pushing the FNR switch away from you to power the electric brake and put the drive unit in reverse. The engine will back up while the EZ Trim Lever is in the forward run position but you will have more power in reverse when the E-Z Trim Lever is lowered. To lower the E-Z Trim Lever put the engine in reverse and start to back up. Now depress the Surface Drive handle downward and push the E-Z Trim Lever near the throttle backwards to let the prop down to the lower position. This will allow the prop to drop about 9" to give you more power in reverse. When you are ready to go forward, depress the handle downward and flip the E-Z Trim Lever forward and flip the FNR switch back to the forward position. It is not necessary to shift into reverse before depressing the Surface Drive handle but it will make it a little easier to depress the Surface Drive handle while in reverse. It is preferred to bring the engine to idle when shifting. (Illustrations below.) **Operating the engine in reverse for an extended period of time can generate a high heat situation and shorten the transmission's oil life.**

EZ Trim Control Lever Forward Position



EZ Trim Control Lever Reverse Position



In the event of an electrical failure, you can use the emergency power supply to bypass a failed electrical component and place the engine in a "direct drive" state that will allow you to send 12 volts directly to the clutch and operate the engine in forward or to the electric brake and operate in reverse. **You must unplug both the electric brake harness and clutch wiring harness if the emergency power supply is being used.** You will not have the option of neutral until you can repair the failed component and will have to rely on raising the prop out of the water for "neutral".

1. Remove the connector cover and cut the tyrap holding all three connectors together.
2. Remove the cap in the emergency power supply and unplug both of the other plugs. Plug the emergency power supply into the clutch wiring harness plug and you can now operate the engine in forward.

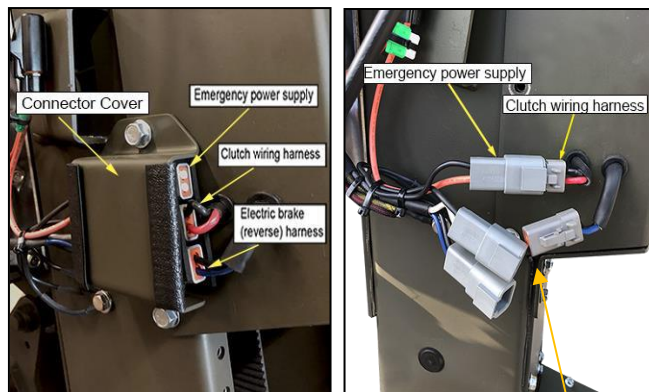

You must unplug both the electric brake harness and clutch wiring harness if the emergency power supply is being used

LUBRICATION

ENGINE LUBRICATION

CHECK ENGINE OIL BEFORE EACH USE. We recommend changing engine oil after the first 10 hours on a new engine and every 50 hours or yearly after that. When changing oil, run the engine to heat the oil before draining. When changing the oil filter always fill the filter with oil before installing. Fill crankcase and then prime the oil pump by spinning the engine with the electric starter for about 10 seconds with the safety kill switch in the kill position. Start the engine and let it idle for a few minutes before speeding up.

Lubricate the engine's throttle linkage on carbureted engines as needed with a WD-40 type spray lubricant. This may or may not be necessary depending on environmental conditions. An occasional spray will help keep the throttle functioning smoothly. EFI engines do not have any linkage to lubricate.

EXTERNAL GREASE FITTINGS

The Surface Drive unit has **3** external grease fittings which require periodic lubrication. One fitting is located on the drive tube and the other two are located on the tilt axis and steering axis (see *photos below*). We recommend using a #1 or #2 marine grade waterproof grease such as AQUA-LUBE to lubricate all fittings.

Grease the steering and tilt axes after every 10-20 hours of run time. Any more often will be excessive and messy. In addition to lubricating the fittings, apply a small amount of grease to the transom clamp bolts yearly or as needed.

The fitting shown in the figure on the right below is used for lubricating the prop shaft and lower bushing and seal system. A pressure lubricator shown to the left of the fitting feeds grease to the system as needed and allows for heat expansion inside the drive tube. See the following section on **PRESSURE LUBRICATION** on page 11 for proper lubrication and maintenance.

The drain plug shown is used to check for water leakage inside the frame housing. This should be checked after your first test run on the water and again each time the panels are removed and reinstalled. While the engine is out of the water, remove the plug and tilt the engine back so that any water inside the housing will drain out of the drain hole. If water comes out when checked, the panels should be resealed with a good grade silicone.

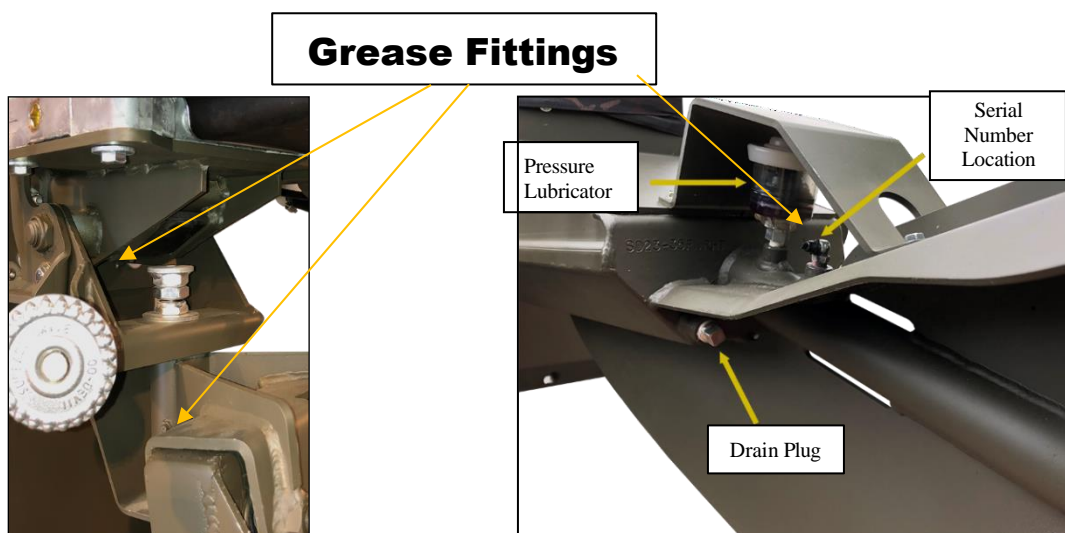

PRESSURE LUBRICATION

A pressure lubricator shown on the previous page is mounted on the upper end of the drive tube and features a spring loaded piston which creates a small amount of grease pressure inside the drive tube. This grease volume lubricates the prop shaft, lower bronze bushing, and lower seals. During assembly the lubricator is intentionally oriented so that the factory grease fitting is inaccessible. Lubricate **ONLY** the grease fitting mounted adjacent to the lubricator to ensure that grease is fed into the drive tube and not just into the lubricator. Pumping grease through this fitting will fill both the drive tube and the lubricator.

- Visually inspect the position of the lubricator piston before and after each use.
- The lubricator should be kept about $\frac{3}{4}$ full so that grease consumption can be easily monitored. The lower drive system should use up very little or no grease at all when functioning properly.
- If the grease level does not seem to change after several hours of run time, pump grease into the drive tube until the piston starts to rise. This ensures that the lubricator piston is not “stuck” and giving a false impression that the tube is full. If the lubricator and drive tube are properly filled, the piston should move upward after only a few pumps of grease.
- The lubricator cannot be damaged by over-lubricating the drive unit. The lubricator is designed so that grease will expel from under the cap if over-filled.
- **ATTENTION: The lubricator piston will not reach the bottom of the cup.** When the piston is at its lowest position, the visual grease column will be approximately 3/8” high. When the piston reaches this level it will no longer supply grease to the tube. In order to insure proper lubrication, the piston must be kept above this level at all times.
- IT IS THE CUSTOMER’S RESPONSIBILITY TO CHECK AND INSURE THAT THE LUBRICATOR IS WORKING PROPERLY!! Remove and clean the lubricator yearly to ensure that it is working properly and the piston is not stuck. If working properly, it should expel grease from the bottom hole when removed.
- **Do not clean the lubricator with a petroleum solvent** such as gasoline, varsol, kerosene, thinner, or carburetor cleaner. Petroleum solvents will destroy the plastic components. Wipe excess grease with paper towels and clean components with mild dishwashing liquid.

SEAL AND BUSHING WEAR

As the lower and/or upper seals start to wear, the unit may start to consume more grease. It may be time to replace the seals if the lubricator ever becomes empty after a normal operation period or requires 10 pumps or more from the grease gun to fill on two occasions. **DO NOT DELAY THIS PROCEDURE!!!** If the drive unit is run without grease, premature wear on the prop shaft and lower bushing will occur and will elevate the cost of repair. The life of the lower seals is determined by how the shaft is lubricated and how abrasive the material is that the engine is run in, such as mud, sand, and silt. Under extensive or commercial use, especially in brackish or salt water, the lower seals should be replaced annually.

INTERNAL DRIVE LUBRICATION

The Surface Drive unit has **4** internal grease fittings located within the frame housing. One fitting is located on each of the two universal joints and also on both the upper bearing housing supporting the prop shaft and on the sprocket shaft bearing housing shown in the photo below.

After every 75-100 hours of use, lubricate the upper bearing housing and the universal joint fittings shown below with 2-3 pumps from a grease gun.

The Sprocket Shaft Bearing Housing shown contains a set of Tapered Roller Bearings. This Housing is sealed and grease lubricated.

After every 75-100 hours of use, remove the clamp holding the vent tube connected to the barb fitting (**Fig. 1**) and pump grease into the grease fitting until grease starts to exit the top of the housing through the vent hose. Collect excess grease with a paper towel and continue pumping grease into the housing until clean grease starts to expel through the vent hose. Run the engine a few minutes to mix the old grease with the new grease and kill the engine and pump with grease again until new grease comes out of the vent tube. Repeat this process three times and replace the vent tube clamp when finished.

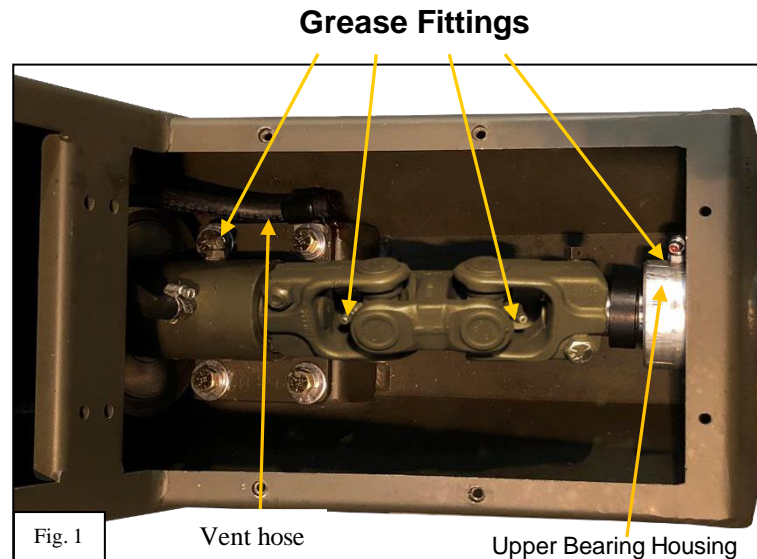

Replace the lower access panel following the same instructions as for the upper panel described on the bottom of page 15. Add an additional amount of Silicone to the corner areas where the bend in the lower access panel mates to the frame. Panels must be sealed properly to keep water out of the frame housing.

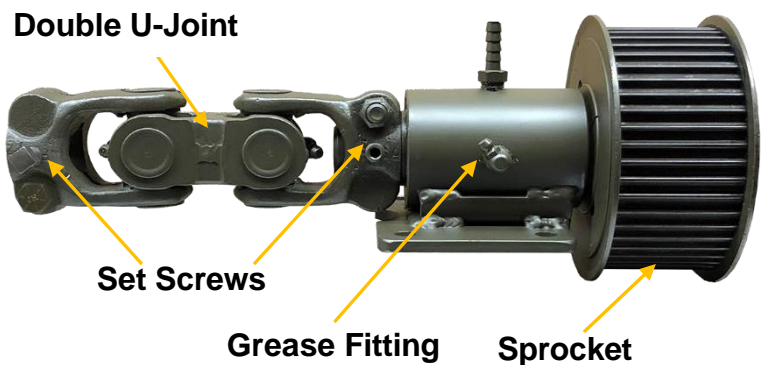

BELT TENSION AND INSTALLATION

TOOLS REQUIRED

Torque Wrench (to 250 Lbs.-In.)
3/8" Socket
9/16" Socket
6" long Socket Extension
3/8" Drive Ratchet
9/16" Wrench
11/16" Crowfoot or open end wrench
3/8" Drive universal joint
Gates Tension Tester

Gates Tension Testers (Part# 7401-0076) are available directly from Go-Devil or any local Gates Dealer. (See page 14 for Instructions)

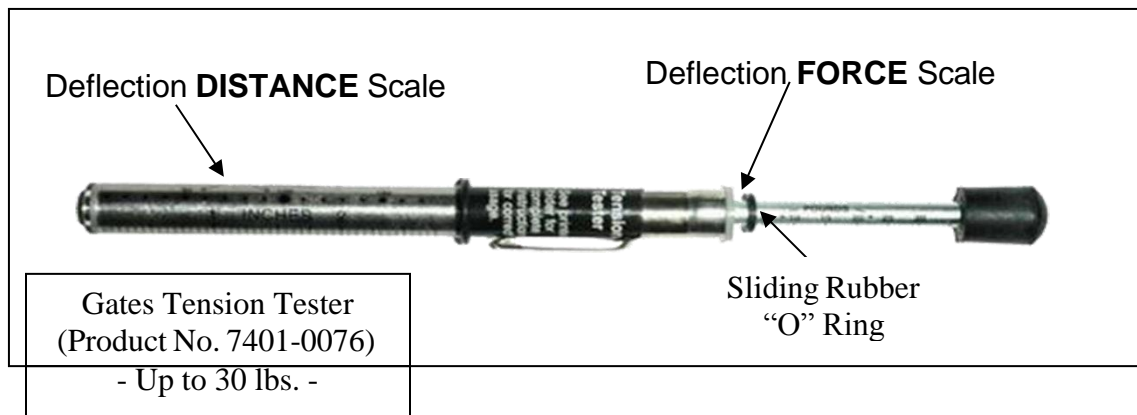

Gates Tension Tester...How it works!

The tension tester is pushed against the center of the belt width through the inspection hole. Pencil type tension testers like this one measures belt tension by showing the force required to deflect the belt a predetermined distance. Force and deflection on Surface Drive Engines should be kept within the tolerance listed below. Belts that are run too loose will cause an increase in driveline vibration resulting in reduced belt life. **When tensioning a new belt, adjust to the high end of the given tolerance to allow for belt stretch. Never tension the belt more than specified! Over-tensioning the belt may cause premature wear or damage to the engine and drive unit bearings. If checking the tension on an existing motor target 17 lbs. for belt tension.**

All FNR Models

Force = 13 - 21 lbs. (Target 17 lbs.) Deflection = 1/4"

CHECKING BELT TENSION

Checking Belt Tension on the Surface Drive does not require removal of the rear access panels. An inspection hole on the side of the frame is provided to inspect and check belt tension from outside of the frame.

Belt tension should be checked every 30-50 hours of run time as described below and readjusted if necessary.

1. Locate the black hole plug on the side of the frame behind the engine.
2. Carefully slip a knife blade behind the plug flange and pry it out of the hole.
3. Use a flashlight to look inside the hole and locate the belt. When using the tension tester, force must be applied to the belt by pushing the tester in the center of the belt width. The inspection hole may or may not be centered on the belt width.
4. Insert tension gauge (Gates # 7401-0076) through the hole in drive housing and set large O-ring $\frac{1}{4}$ " from the frame. **Be sure to use the inch scale and not the metric scale on the tester. (Fig. 1)**
5. Slide small O-ring against the large part of the gauge. Make sure the tension gauge is in the middle of the belt. Push the gauge in until the large O-ring touches the housing. Remove the tester from the hole and view the small sliding "O" ring location on the force scale. The force applied to deflect the belt is indicated by the location of the bottom of the "O" ring on the force scale. **(Fig. 2)**
6. Repeat steps 4-5 at least three times or until you achieve the same result for each measurement.
7. **The desired tension is 13-21 pounds with a target of 17 pounds with $\frac{1}{4}$ " deflection on an existing belt using Gates belt gauge # 7401-0076. If the belt tension is less than 13 pounds it will be necessary to adjust belt. Tension a new belt to 21 lbs. to allow for stretching. A new belt will stretch over night without running the engine.** If the measured force falls below specs shown below, re-tension the belt as described on the following page (15).

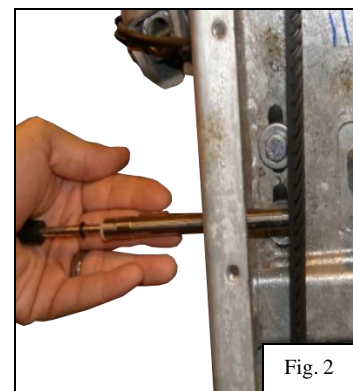
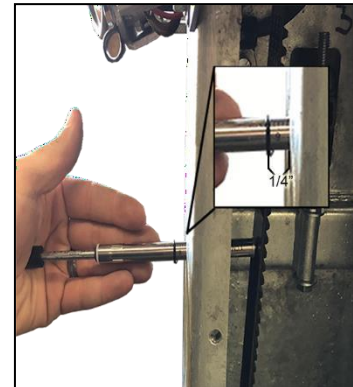

All FNR Models

Force = 13-21 lbs.

Deflection = $\frac{1}{4}$ "

ADJUSTING BELT TENSION

1. To adjust the belt, remove the top panel and two lower panels shown in Fig. 1. The lower panels are sealed with Loctite 598 High Performance RTV Silicone Gasket Maker. The panel will need to be pried from the frame with a large screwdriver. **(Fig. 1)**

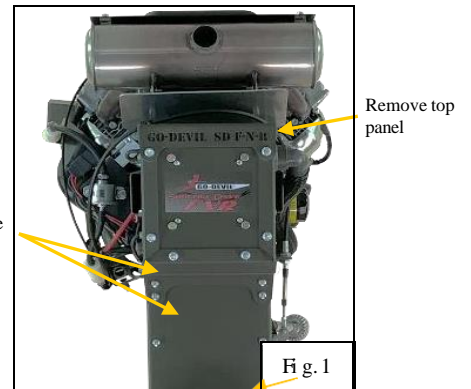

2. Loosen all eight frame housing bolts. **(Fig. 2 has the brake plate removed so you can see the bolts easier. It is not necessary to remove the brake for belt adjustment.)** The top set of 3 bolts go into the back of the engine. Loosen the two top bolts with the universal joint, 6" extension, and 5/8" socket. **(Fig. 3)** The bottom four hold the engine plate onto the frame. The lower right of that set is a stud with a nut welded on it. It is a lot easier to use an 11/16" crowfoot wrench on this bolt but an open-end wrench can be used. Adjust the nuts on the vertical 3/8" x 6" bolt to tighten the belt. Move about 1/2 turn on the nut and recheck tension. Repeat until desired tension is reached. When tension is reached tighten all eight frame bolts to 250 in.-lbs. (21 ft.- lbs.) and recheck tension again. If it is too tight or too loose adjust again.

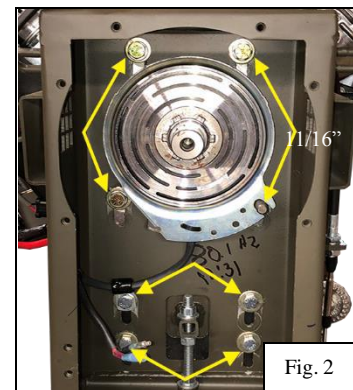

3. **NEW BELT ONLY** - If installing a new belt, loosen the lower adjustment nut and turn the Upper adjustment nut clockwise to loosen the belt. Remove all four of the 3/8" bolts securing the sprocket shaft bearing housing shown on page 12. The sprocket unit can then be lifted enough to change the belt. Reinstall them with the new belt in place around the sprocket. Torque all four bolts to 250 In.-Lbs. (21 Ft.-Lbs.)

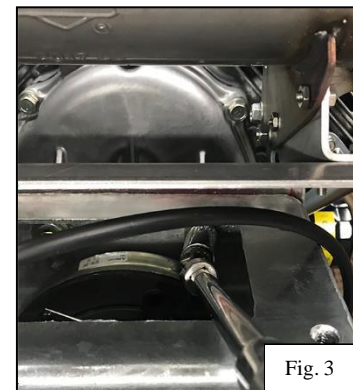

4. Remove all existing RTV Silicone from frame and access panel and insure that mating surfaces are clean. Apply a continuous 1/8" bead of silicone to the frame surface and inside the bolt holes. Ensure that the bead is continuous around the perimeter to prevent water leakage. **(Fig. 4)**

5. Install the Access Panel and lightly tighten the 1/4" bolts. Allow Silicone to cure for several hours and then torque all bolts to 125 In.Lbs. (10Ft.- Lbs.)

6. After running your engine for the first time after sealing the lower cover plates, remove the frame drain plug next to the shaft housing to check for any water leakage. If any water come out of the drain plug, you need to remove the lower cover plates and re-seal it.



SPECIAL TOOLS TO SERVICE SURFACE DRIVES

PART #	DESCRIPTION	USED FOR	PRICE
DIE114X1	1-1/4" HEX DIE	HEX DIE (TO REPAIR SHAFT TUBE THREADS)	\$100
SHBUPU	PULLER FOR SHAFT & BUSHINGS (SLIDE HAMMER)	USED WITH: SHAFT ADAPTER TO REMOVE SHAFT BUSHING PULLER- TO REMOVE BUSHING- (MUST USE 1-1/8" TAP TO THREAD INNER BUSHING FOR BUSHING PULLER INSERTION.)	\$50
SHAD	SHAFT ADAPTER	USED WITH PULLER TO REMOVE SHAFT	\$15
BUPU1	BUSHING PULLER	USED WITH PULLER TO REMOVE BUSHING	\$20
BUIN1	BUSHING INSTALLER	TO INSTALL BUSHINGS	\$10
T118	1-1/8" TAP	USED TO THREAD INNER BUSHING FOR INSERTION OF BUSHING PULLER FOR REMOVAL OF BUSHING.	\$60
R1	1" REAMER	AFTER BUSHING INSTALLATION, USED TO REAM THE BUSHING FOR PROPER SHAFT PLACEMENT/FIT.	\$70

TOTAL \$325.00

These tools can be rented for \$20.00 plus shipping with a \$325.00 deposit.

OTHER TOOLS NEEDED TO SERVICE FNR SURFACE DRIVES

18" PIPE WRENCH
 1/2" DRILL
 8" OR 10" CRESCENT WRENCH
 1-1/16" SOCKET OR COMBINATION WRENCH
 1-1/8" DEEP SOCKET OR COMBINATION WRENCH
 PAIR OF CHANNEL LOCK PLIERS
 4 TO 5 LB HAMMER
 5/16" DRILL BIT
 1-1/4" X 6-1/2" LONG PVC PIPE (to install lower seals)
 11/16" CROWFOOT (to loosen and tighten engine housing to frame)
 1/2" x 3/4" ADAPTER FOR SLIDE HAMMER (to remove transmission)
 3/4" SHAFT SLIDE HAMMER
 2- 1/2" BOLTS 2 -1/2" long (to lock transmission when torquing bolts)
 3/16" HEX SOCKET DRIVER (to tighten brake disc bolts)
 1/8" HEX SOCKET DRIVER (for transmission drain plug)
 5/32" HEX SOCKET DRIVER (for installing transmission housing to sprocket)
 TWO STRIPS OF .063" MATERIAL (for setting brake shoes)
 NEVER SIEZE
 BLUE LOCTITE
 SYRINGE TO FILL GEARBOX

CHANGING TRANSMISSION GREASE/OIL

(Updated 4/24/2023)

1. Remove the top and rear cover plates on drive housing. It is not necessary to remove the bottom cover plate that attaches to the lubricator guard. **(Fig.1)**

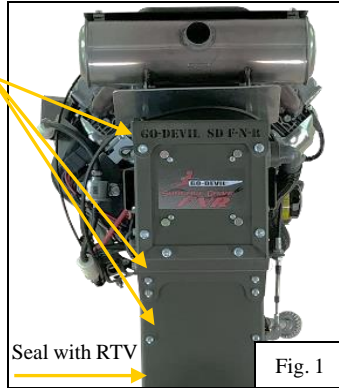

2. Place clean rags or paper towels between the belt and transmission to catch any oil you may spill. **(Fig. 2)**

3. To drain the gearbox with grease, you must remove one drain plug, rotate it to the top and add 4 oz of diesel to the gearbox. **(Fig. 3)**



4. Install the drain plug and run the unit in reverse 3-5 minutes until the gearbox gets warm or hot.

5. You can now remove each drain plug and drain the gearbox.

6. Using a cut off water bottle, drain the gearbox. **(Fig. 4)**



7. To install the grease, you will need a #2 O-ring boss fitting with a grease fitting installed in it. Our part # is FNRGRF. Rotate the fitting to the 6 o'clock position.

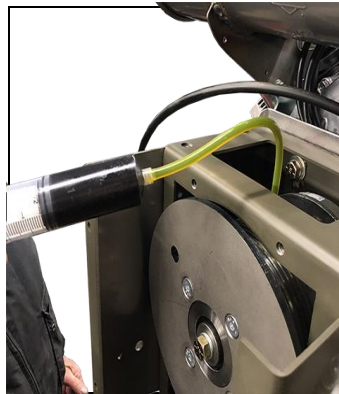

8. We now use 1-1/2 oz of Mobil 1 Synthetic grease with 1/4 oz of Lucas oil stabilizer. This will mix when running in neutral and reverse. No gears are turning when in forward.



9. You will remove each drain plug and screw the grease fitting into a drain hole and rotate it to the bottom to the 6 o'clock position to pump the 1-1/2 oz of Mobil 1 Synthetic grease in.

10. Remove the fitting and install the drain plug.

11. Add in the 1/4 oz of Lucas stabilizer into the drain hole on the top of the gear box with a syringe.

12. Install the second drain plug. Run in neutral and reverse to mix the oil and grease.

13. Leave the top cover off and test run with a piece of cardboard on top of the frame to check for leaks while running at half speed or higher in forward, neutral and reverse.

14. Replace the grease/Lucas mix every 100 hours when you service the sprocket shaft bearings and u-joints. **(Fig. 5)**
15. Reinstall the covers using a good grade RTV silicone on the back cover. **(Fig. 6)**
16. After running your engine for the first time after sealing the lower cover plates, remove the frame drain plug next to the shaft housing to check for any water leakage. If any water come out of the drain plug, you need to remove the lower cover plates and re-seal it.

100 hours is the recommended change interval for the transmission under normal conditions. If your engine is being used excessively in reverse you should change the oil every 50 hours.

CLUTCH AND TRANSMISSION REMOVAL

1. Remove the top, back covers, wiring harness cover and brake plate assembly. You can remove the side covers and brake plate in one piece. **(Fig.1)** Hang the brake plate assembly from the lift eye on the frame. **(Fig. 2 and 2a)**
2. Refer to steps 2-4 of **“Changing Oil in FNR Gearbox”** to drain the oil from the gearbox before proceeding.
3. Remove the 4 bolts in the bearing unit using a 9/16” socket to relieve the belt tension. Doing this will allow you to reinstall the belt without needing to tension it again **(Fig. 3)**
4. Insert two 1/2” bolts through the brake plate into the machined stops on the transmission to lock the transmission in place. Insert a large screwdriver between the bolts. **(Fig. 4)**
5. Loosen the center bolt on the transmission with a 5/8” socket but do not remove the bolt.
6. Remove the four socket head screws attaching the brake plate with a 3/16” hex bit socket by holding the 1/2” bolts with a large screwdriver and remove the brake plate and 5/8” bolt you loosened in step 5. **(Fig. 5)**
7. Screw the 1/2” x 3/4” adapter into the center of the crankshaft extension and pull the transmission out with the slide hammer. **(Fig. 6)**
8. Slide the transmission housing off of the crankshaft. **(Fig. 7)**

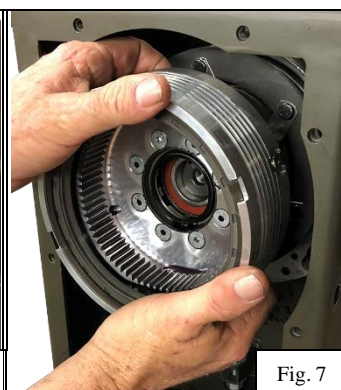
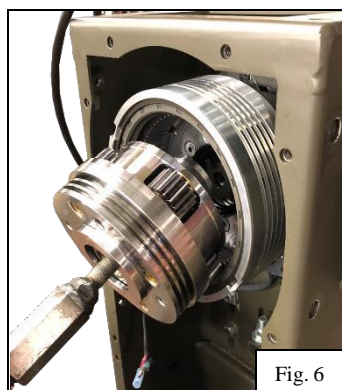
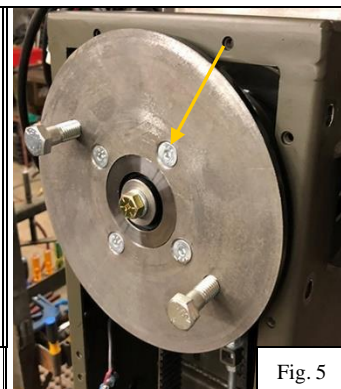
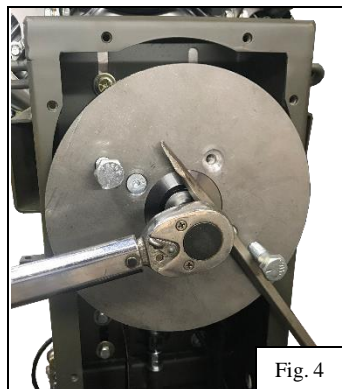
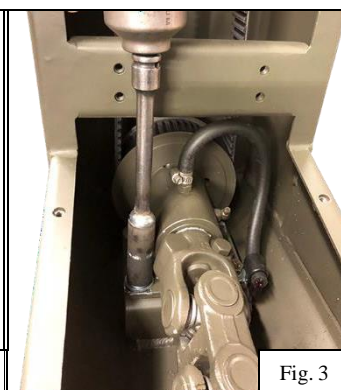
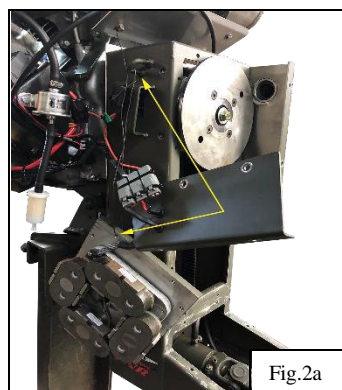
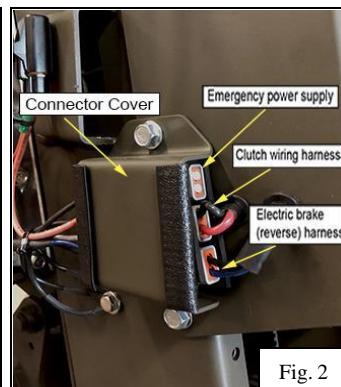
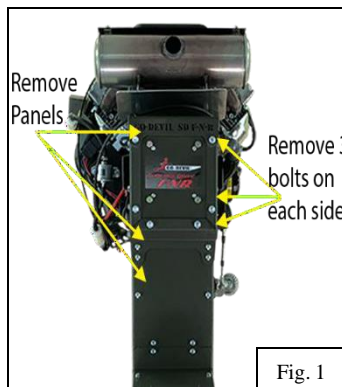

9. Slide the rotor assembly off of the crankshaft. **(Fig. 8)**
10. Disconnect the rubber coated clamps holding the clutch wire. **(Fig. 9)**
11. Slide the Field Assembly off of the crankshaft. **(Fig 10)** Make sure not to lose the clutch spacer behind the Field Assembly marked with an arrow in **(Fig. 11)**

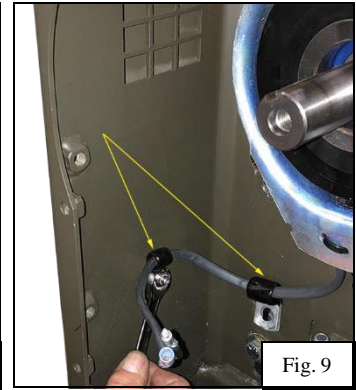
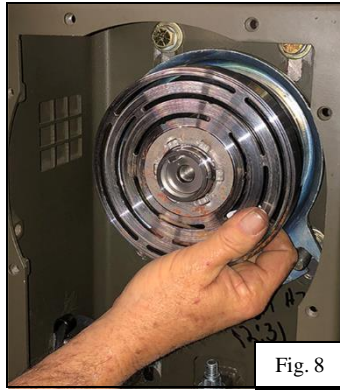

CLUTCH AND TRANSMISSION INSTALLATION

1. Install the clutch spacer with the bevel towards the engine. Add a light coat of never seize to the full length of the crankshaft. **(Fig.1)**
2. Slide on the clutch field assembly first, then the rotor assembly. **(Fig.2)**

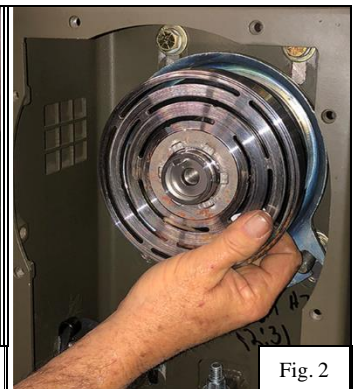

3. Apply a light film of oil (oil for Transmission is Mobil 1 4T Racing Oil) on the two seals in the transmission housing. Slide the sprocket/transmission housing onto the crankshaft. **(Fig.3)**

4. Install the key with the square side in the crankshaft by holding it with a needle nose pliers and tapping it in with a hammer. **The key will be tight. Do not file the key for a loose fit!** The key can be partially installed when installing the shaft extension. With the sun gear it will slide the key all the way in. **(Fig. 4)**

5. Slide the shaft extension onto the crankshaft with the key lined up with the slot and tap in with a rawhide or rubber hammer until it bottoms out. **(Fig. 5)**

6. Add a film of oil on the seal in the planet gear assembly. Now slide in the planet gear assembly onto the crankshaft. You will need to rotate it for the gears to line up. After it is pushed in, it will have a cushion of air inside holding it from bottoming out. This is not a problem. You could remove the fill/drain plug from the outer housing to relieve this cushion. **(Fig. 6)**

7. Install the 5/8" center bolt with the heavy machined washer and lock washer as shown with Red #263 Loctite. Tighten snug with a wrench and you will torque it after disc installation. **(Fig. 7)**

8. Install the belt over the transmission assembly and onto the bottom sprocket. It will be necessary to remove the four bolts in the bearing unit to enable you to install the belt onto the bottom sprocket and to tighten the eight-frame mounting bolts after adjusting the drive belt. If the belt becomes tight when tightening the bearing unit down loosen the 8 bolts that secure the engine and



Fig. 3

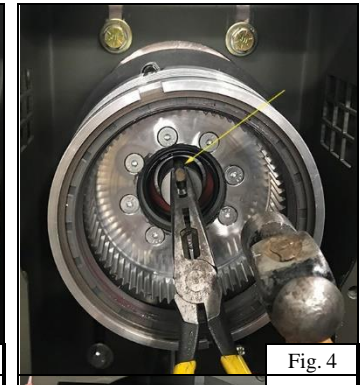

Fig. 4



Fig. 5

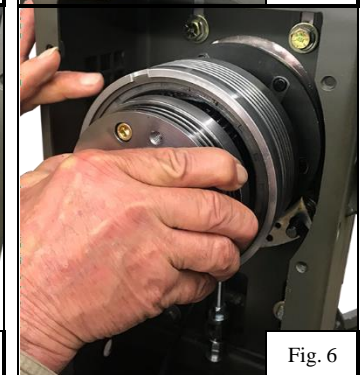

Fig. 6

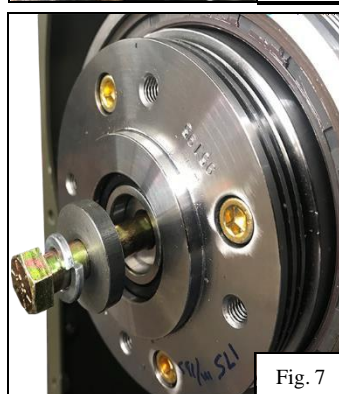

Fig. 7

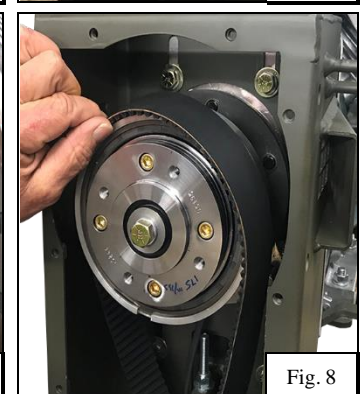

Fig. 8

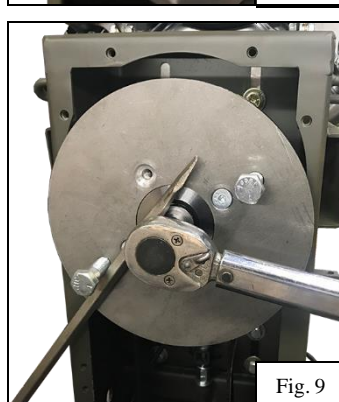

Fig. 9



Fig. 10

engine mount to the frame and adjust tension bolt to give the belt slack. **Do not tension the belt until the crankshaft bolt is torqued to the proper torque! (Fig.8)**

9. Install the brake disc with two of the socket head screws installed. Do not use Blue Loctite yet because this part of assembly is temporary. Insert two 1/2" bolts into the through holes in the disc and into the slots machined into the outer transmission housing. Using a large screwdriver as shown in **(Fig. 9)** torque the center bolt to 78-foot lbs.

10. Remove the brake disc and adjust the drive belt until it becomes tight. Refer to Page 14 and 15 "Checking the belt tension" and "adjusting the belt tension" and follow the steps to properly tension the belt.

11. Remove a fill/drain plug from the transmission and rotate the hole to 12 o'clock. **(Fig. 10)** Fill the transmission with 1-1/2 oz of Mobil 1 4T 10W-40 Racing Oil using a syringe with a hose. **(Fig. 11)** (syringe is provided with each engine when shipped) Reinstall the fill/drain plug. Install the brake disc using the four 5/16" socket head screws using a 3/16" hex socket with Blue Loctite and the two 1/2' bolts and large screwdriver to hold disc. Torque the socket head bolts to 200-inch lbs. or 16.6-foot lbs. **(Fig. 12)**

12. Reinstall the brake assembly. **(Fig. 13)** Check the clearance of the brake shoes to the brake plate. The required clearance is .063". We use two strips of .063" material long enough to check the clearance on all four brakes at once. To adjust the clearance, you must loosen the 4 cap screws using a 1/2" socket. Then you screw in the socket set screws until the brake shoes push the .063" strips against the brake plate. **(Fig.14-15)** Now torque the four cap screws to 200 In. Lbs. to secure the adjustment. If you do not have these strips you can loosen the four cap screws with a 1/2" socket and screw the socket set screws in until the brake pads touch the brake plate. Now unscrew the set screws one full turn on each screw and torque the cap screws to 200 In. Lbs. The set screw is 3/8" x 16 threads per inch. One full turn = .063"

13. Refer to **PAGE 17 steps 6-7** to re-seal the cover plates on the frame.

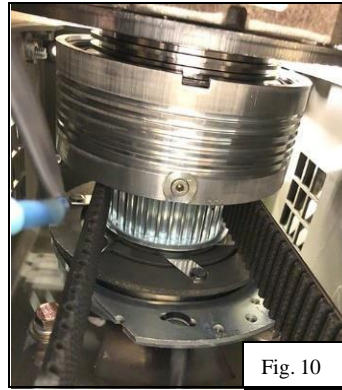

Fig. 10

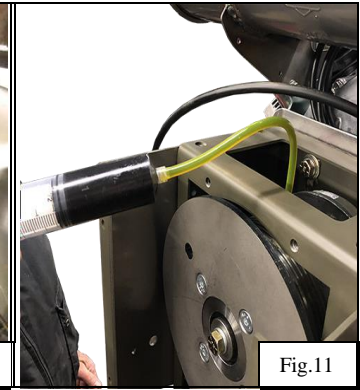

Fig.11

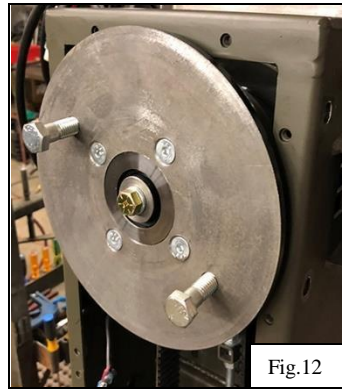

Fig.12

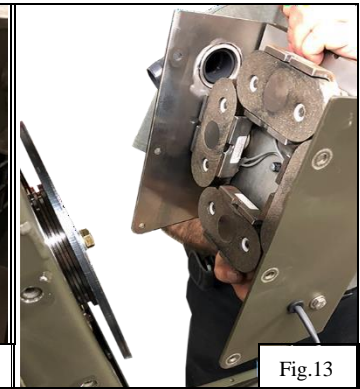

Fig.13

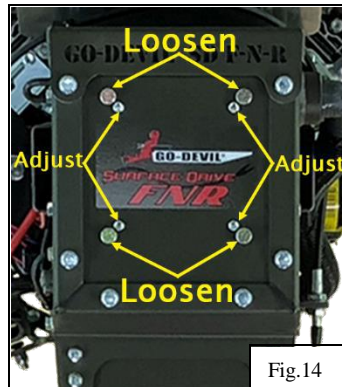

Fig.14

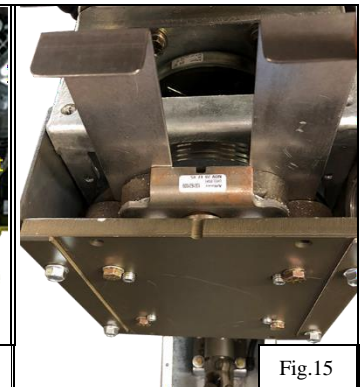

Fig.15

LOWER SEAL REPLACEMENT

1. Determine if the lower bushing should also be changed by holding the cavitation plate with one hand and moving the propeller up and down then left to right with the other hand. If no movement is felt, there is no wear in the bushing. Once the movement becomes 1/16" or more, it will be necessary to replace the bushing.
2. Remove the propeller and unscrew the lower seal housing cap (LHC1) (Refer to PAGE 23 Propeller Removal)
3. Remove the lower housing cap (LHC1 **which has left hand threads**). (It must be turned clockwise to remove it.) Clean thoroughly of any grease or Loctite.
4. Pick old seals out with a tool such as an ice pick with a 90-degree bend on the end. We prefer not to remove the seal housing from the shaft outer housing. (See note at the bottom of the page if the lower seal housing is removed.)
5. Pack the first seal with grease and insert it into the housing with the spring-side facing the engine and screw the seal on over the threads on the shaft. **(Fig. 1)** These seals can be pushed in with a 1-1/4" schedule 40 PVC pipe cut 6-1/2" long. This procedure may shave a small amount of material off of the outside diameter of the seal. **(Fig. 2)** Insert the next seal with the spring facing the prop. Pack the area between the two seals with a small amount of grease and use the same PVC pipe to push the seal in completely.
6. Install the new scraper seal (1SC) into the lower housing cap (LHC-1) and install onto the lower seal housing (LSH175-1) with blue Loctite on the threads by turning it counter-clockwise (left-hand threads). **(Fig. 3)**
7. Pump the grease fitting on the shaft housing until the lubricator is about 3/4 full.
8. Apply never seize to the hex shaft and slide the propeller on. You may need to tap it with a hammer to seat completely.
9. Install a 3/4" brass washer on the shaft and then screw the jam nut tight. Screw on the nylon insert nut and tighten.

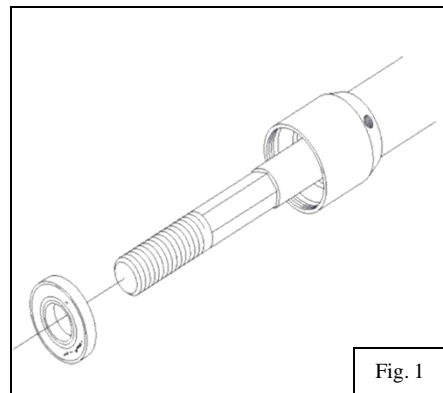
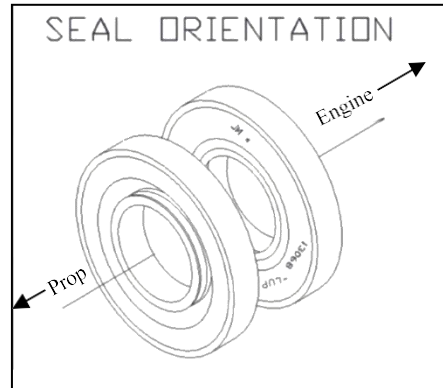

Fig. 1

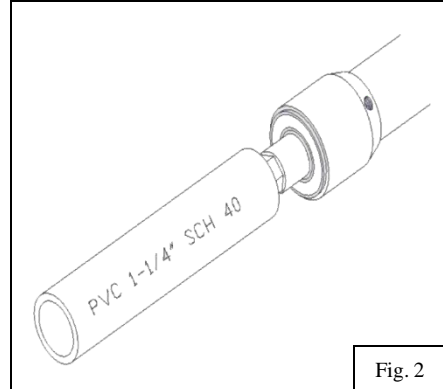

Fig. 2

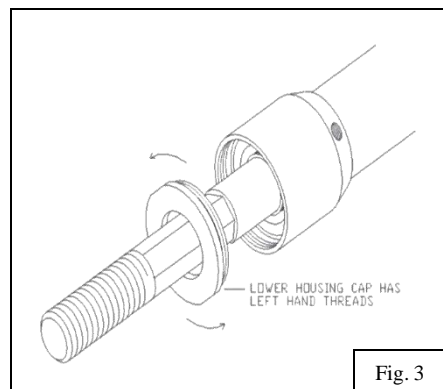

Fig. 3

INSTALLING THE LOWER SEAL HOUSING

1. Remove any excess silicone from the shaft housing and inside the lower seal housing.
2. Add a good grade of silicone to the bore in the front of the lower seal housing and a small amount on the threads of the drive shaft housing.
3. Screw the housing on by hand until it bottoms out. Now tighten it with a large pipe wrench extremely tight.
4. After tightening apply blue Loctite to the 14x14SS set screw and tighten it into the front edge of the edge of the lower seal housing.
5. Remove all excess silicone inside the housing. **Any excess silicone can plug the return groove on the lower bronze bushing return groove on the lower bronze bushing and cause the lower seals to leak.**

PROPELLER REMOVAL

1. Remove first nut with a 1-1/16" socket or wrench.
2. Remove the second nut with a 1-1/8" wrench or deep socket.
3. Slide off the 3/4" brass washer
4. Tap the prop off of the shaft with a rawhide or rubber hammer. You can also use a block of wood between the prop and a metal hammer if necessary.

PROPELLER INSTALLATION

1. Lubricate the hex and threads with a thin coat of never seize.
2. Slide the prop onto the shaft. It may be necessary to bump the prop onto the shaft to seat the prop over the 1" diameter part of the shaft.
3. Slide the 3/4" brass washer over the threads.
4. Screw the 1-1/8" nut onto the threads and tighten.
5. Screw on the 1-1/16" nylon lock nut and tighten.

SHAFT REMOVAL

1. Leave the engine mounted on your boat in the trailering position or clamped to a solid saw horse. Remove propeller, all nuts, and washers. (Refer to PAGE Propeller Removal.)
2. Remove the lower cover plate to access the shaft and yoke.
3. Remove the set screw in the yoke clamped to the prop shaft. **DO NOT REMOVE THE SET SCREW FROM THE FRONT YOKE!**
4. Loosen the bolt in the split yoke with two 9/16" wrenches. Drive a flat-head screwdriver into the split yoke as parallel to the shaft as possible. **DO NOT DRIVE IN PERPENDICULAR OR AT A RIGHT ANGLE TO THE SHAFT!**
5. Loosen the set screw on the eccentric collar on the upper bearing. Now rotate the eccentric collar clockwise (standing from rear of engine) using a 1/8" pin punch or center punch. (The collar can tighten in either direction.)
6. Install the propeller and nut and bump shaft out with a rubber mallet or rawhide hammer by tapping on the propeller.

SHAFT INSTALLATION

1. Slide the shaft through the housing slowly until it comes out of the upper bearing housing. Slip the eccentric collar over the shaft and leave it loose.
2. Install the shaft key $\frac{3}{4}$ of the way into the yoke and slide the shaft to the yoke with a pair of channel locks. Now tap the shaft in about $\frac{3}{4}$ " with a $\frac{3}{4}$ " coupling nut or our shaft puller. At this point, remove the lubricator and fill the tube with grease until grease comes out at the grease fitting. Now install a 1/8" pipe plug and finish filling the tube slowly until grease starts coming out of the lower bushing. At this time we recommend removing the pressure lubricator and taking it apart and cleaning it thoroughly. Use paper towels or soap and water, no solvents. Stretch the spring to insure proper pressure.
3. Now install the lower seal housing by applying silicone inside the lower seal housing, in front of the threads. Tighten the lower seal housing with a pipe wrench and install the set screw with blue Loctite. Install the lower seals as described on PAGE 22. Install the prop using steps 1-5 in "**PROPELLER INSTALLATION**" on PAGE 23. Now drive the shaft in until you have 1/8" to 3/16" air gap between the prop and the LHC1.
4. Countersink the set screw hole in the split yoke with a 5/16" drill bit. Tighten the bolt on the yoke at this time using two 9/16" wrenches extremely tight. Install the set screw. Install the lower seal housing cap and fill the pressure lubricator until it is $\frac{3}{4}$ full. You are now ready to install the propeller.

BUSHING REMOVAL AND INSTALLATION WITH OUR TOOLS

1. Remove the shaft and lower housing.
2. Using the 1-1/8" tap, screw it into the bushing. This will cut threads in the bushing to fit the bushing puller (#BUPU1).
3. Screw the bushing puller (#BUPU1) into the bushing. Screw the shaft puller (#SHBUPU) into the bushing puller.
4. Using the slide hammer on the shaft puller, remove the bushing.
5. Drive the new bushing in with our bushing installer (BUIN1) and a four to five-pound hammer.
6. The bushing will need to be reamed with a 1" reamer or 1" drill bit to allow the shaft to spin freely. The goal is to have a .001 to .002 tolerance between the shaft and the bushing.

BUSHING REMOVAL AND INSTALLATION WITHOUT OUR TOOLS

SPECIAL ITEMS NEEDED

- 1 sabre saw or sawzall with blade to cut bronze
- 1 7/8" bolt (any length)

1. Remove the shaft and lower housing.
2. Using a saw, split the bushing at two locations. Be careful not to cut the shaft housing. After the bushing is split, pull out the two pieces with a pair of pliers.
3. Insert a 7/8" bolt into the bushing using it as a bushing installer. Drive the bushing in with a four or five-pound hammer.
4. The bushing will need to be reamed with a 1" reamer or 1" drill bit to allow the shaft to spin freely. The goal is to have a .001 to .002 tolerance between the shaft and the bushing.

QUANTITY	PART NO.	DESCRIPTION
2	9-8A	1" SPLIT END YOKE
2	38112NFG5	3/8"X1-1/2" NF CAP SCREW
2	38LNNF	3/8" NF LOCKNUT
1	12	3/8"-16 SQUARE HEAD SET SCREW
1	3812SSS	3/8"-16 X 1/2" SOCKET SET SCREW
2	10	UNIVERSAL JOINT
1	10A	CENTER YOKE
1	UB-1	1" UPPER BEARING WITH COLLAR
1	7-1	1" UPPER GREASE SEAL
1	21	1/4"-28 GREASE FITTING
1	UBH-1	1" UPPER BEARING HOUSING
1	LUBE	PRESSURE LUBRICATOR
1	21D	1/8 NPT GREASE FITTING 90 DEGREE
1	5-1-1.375	1" LOWER BUSHING W/ SPIRAL GROOVE
1	14X14SS	1/4"X1/4" SET SCREW 18-8
1	LSH175-1	LOWER SEAL HOUSING 1" SHAFT
2	4B-1	1" SEALS
1	1SC	1" SCRAPER SEAL
1	LHC-1	1" LOWER HOUSING CAP
1	11X123BLHX	11X12 3 BLADE PROP W/ HEX SS
1	BW-34	3/4" BRASS WASHER
1	1A2	3/4" JAM NUT
1	1	3/4" NYLON LOCK NUT
1	6-35SDFNR	1" HEX DRIVE SHAFT SS
1	14	1/4" UNDERSIZE KEY

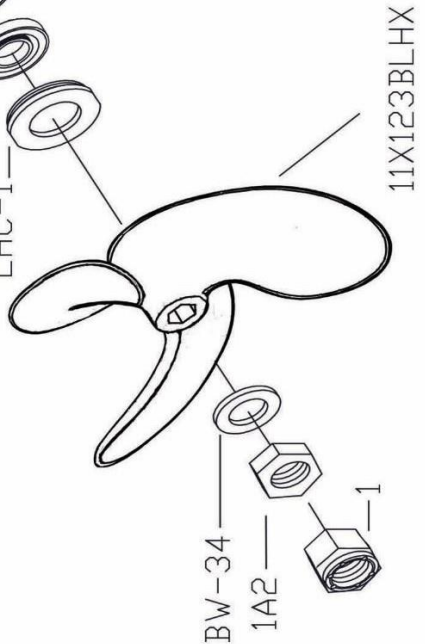
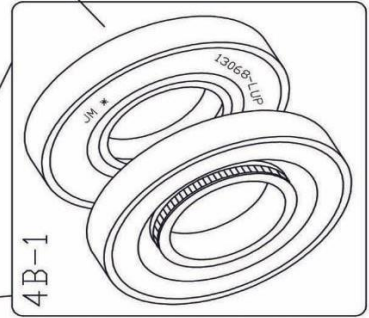
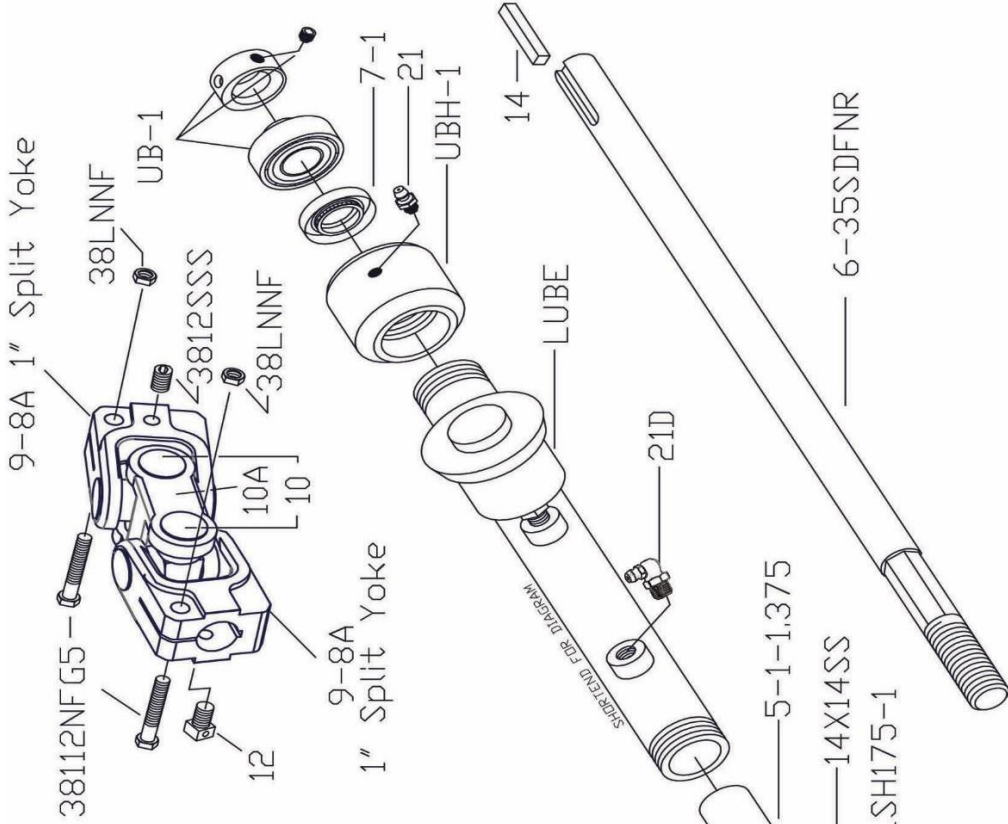

SEALS MUST BE INSTALLED AS SHOWN

**GO-DEVIL SD FNR
LOWER DRIVE ASSEMBLY**

SERVICE MEMOS

Engine handle pulling while on plane.

If you are having problems with the handle pulling to one side while operating the engine it is an easy fix. You may have to fine tune the offset bend in the skeg to correct this issue. If the handle is pulling to the starboard side (right) of the boat, the skeg needs to be bent more to the port (left) side. Use a 12" crescent wrench to perform this procedure. Test-run the boat with the load level and no cross wind until the boat tracks straight without pulling. Do not move the engine on the transom to try and correct handle torque!

Throttle freezing issues.

Surface Drive throttles have been found to have issues with freezing and not operating in very cold temperatures. Moisture enters the cable by rain or condensation etc. and freezes when the ambient temperature is below freezing.

To remedy this:

1. Raise the handle to a vertical position.
2. Remove the black plastic cap at the top of the throttle cable.
3. Using a hypodermic needle, inject antifreeze down the side of the inner throttle cable.
4. Squeeze throttle to move the cable back and forth and work in the antifreeze. This will prevent the cable from freezing anymore.
5. Repeat this procedure multiple times until you can no longer inject any antifreeze into the throttle cable.

ENGINE OIL CAPACITIES

Engine Model	Capacity
23hp Briggs & Stratton Vanguard Model #: 386447	46-48 ounces or 1.43-1.5 quarts with filter
25hp Kohler Command Model#: CH740S	54-61 ounces or 1.7-1.9 quarts Kohler oil
35hp, 37hp, and 40hp Briggs & Stratton Vanguard Model#: 613477, 61E477, 61G477	78-80 ounces or 2.43-2.53 quarts

NOTE: THESE OIL CAPACITIES ARE LISTED IN THE ENGINE MANUFACTURER'S MANUAL. DO NOT RELY ON THESE MEASUREMENTS ALONE. ALWAYS HOLD THE ENGINE PERFECTLY LEVEL AND CHECK THE OIL LEVEL ON THE DIPSTICK MAKING SURE IT IS NOT OVER-FILLED OR UNDER-FILLED.

ALL 23HP ENGINES WILL NOT RUN IF THEY ARE OVER-FILLED WITH OIL.

SERVICE RECORD

ENGINE MAKE _____
 ENGINE MODEL # _____
 OIL FILTER # _____
 FUEL FILTER # _____

VALVE CLEARANCE:
 INTAKE _____
 EXHAUST _____
 SPARK PLUG # _____

OIL CHANGE

DATE

HOURS

OIL CHANGE

DATE

HOURS

SERVICE WORK PERFORMED

Warranty

This warranty replaces any warranties before May 1, 2018

Go-Devil Manufacturing Company of Louisiana LLC. will repair or replace any components on the Go-Devil FNR drive unit that we manufacture at no charge for a period of one year that is defective in materials or workmanship. Transportation charges on parts submitted for repair or replacement under this warranty must be borne by the owner of the unit. This warranty does not cover normal wear, abuse, neglect, or failure due to the elements of nature, such as salt water corrosion. Wear on the shaft and/or bushing due to the lack of lubrication will not be covered by this warranty! See your Service Manual for the proper lubrication instructions.

Please refer to your Briggs & Stratton, Kohler, or Honda engine manual for engine warranty information. An engine warranty can be handled through any small engine dealer in your area that is an authorized warranty service dealer for the brand of engine that you have on your unit. Go-Devil Manufacturing Company of Louisiana LLC. is authorized to warranty all the engines that we sell on our products. In many cases, we can expedite a repair by sending the part to you because most warranty repairs are as simple as replacing a simple part. You will however, be required to return the defective part to us. At that point, we will file the warranty claim directly to the engine manufacturer at no charge to you.